



MERLIN



First Quarter 2026 Earnings

MAY 14 2026

NASDAQ: MRLN

Forward -Looking Statements & Non-GAAP Definitions

This presentation contains "forward-looking statements" within the meaning of the Private Securities Litigation Reform Act of 1995, as amended. We intend such forward-looking statements to be covered by the safe harbor provisions for forward-looking statements contained in Section 27A of the Securities Act of 1933, as amended (the "Securities Act"), and Section 21E of the Securities Exchange Act of 1934, as amended. All statements other than statements of historical facts contained in this presentation are forward-looking statements, including without limitation statements regarding our business strategy, expected growth, future operations and financial performance, anticipated timing of commercialization of our autonomous flight technology, our ability to obtain and maintain regulatory approvals, our expected cash runway, and other plans and objectives of management for future operations. Such statements can be identified by the fact that they do not relate strictly to historical or current facts. When used in this presentation, words such as "anticipate," "believe," "continue," "could," "estimate," "expect," "intend," "may," "might," "plan," "possible," "potential," "predict," "project," "should," "strive," "would," "strategy," "outlook," the negative of these words or other similar expressions may identify forward-looking statements, but the absence of these words does not mean that a statement is not forward-looking.

We have based these forward-looking statements largely on our current expectations and projections about future events and trends that we believe may affect our financial condition, results of operations, business strategy, short-term and long-term business operations and objectives, and financial needs. These forward-looking statements are neither promises nor guarantees, and are subject to a number of important factors that could cause actual results to differ materially from any future results, performance or achievements expressed or implied by the forward-looking statements, including without limitation: our ability to realize the expected benefits of the Business Combination; our ability to maintain the listing of our Common Stock on Nasdaq; our public securities' potential liquidity and trading; our ability to raise financing in the future and to comply with restrictive covenants related to long-term indebtedness; our ability to retain or recruit, or to effect changes required in, our officers, key employees or directors; our reliance upon the efforts of our Board and key personnel to be successful; our limited operating history; expectations regarding the time during which the Company will be an "emerging growth company"; failure to manage our growth effectively; competition from existing or new companies; changes in the market for the Company's products and services and our ability to effectively compete in the aviation technology industry; unsatisfactory safety performance of our non-human pilot system, Merlin Pilot, or security incidents at our facilities; failure of the market to achieve the growth potential we expect; our customer concentration; our reliance on a limited number of suppliers for certain materials and supplied components; failure of our products to operate in the expected manner or defects in our products; our history of losses and failure to achieve profitability in the future; counterparty risks on contracts entered into with our customers and failure of our prime contractors to maintain their relationships with their counterparties and fulfill their contractual obligations; failure to comply with laws and regulations relating to various aspects of our business and any changes in the funding levels of various governmental entities with which we do business; failure to protect the confidentiality of our trade secrets and know how; failure to comply with the terms of third-party open source software our systems utilize; our ability to maintain an effective system of internal control over financial reporting, and remediate existing material weaknesses; the U.S. government's budget deficit and the national debt, as well as any inability of the U.S. government to complete its budget process for any government fiscal year, and our dependence on U.S. government contracts; failure to comply with U.S. export and import control laws and regulations and U.S. economic sanctions and trade control laws and regulations; uncertain global macro-economic and geopolitical conditions and rising inflation; delays or disruptions from changes in the certification process, potential government shutdowns, budget reductions, and shifting regulatory priorities, which could jeopardize customer commitments and milestones, postpone commercialization, and adversely affect our business, results of operations, and financial condition; and the other factors detailed under the section entitled "Risk Factors" of our final prospectus, dated April 21, 2026, filed with the Securities and Exchange Commission (the "SEC") on April 21, 2026.

Any forward-looking statements made herein speak only as of the date of this presentation, and you should not rely on forward-looking statements as predictions of future events. Although we believe that the expectations reflected in the forward-looking statements are reasonable, we cannot guarantee that the future results, performance, or achievements reflected in the forward-looking statements will be achieved or will occur. Except as required by applicable law, we undertake no obligation to update any of these forward-looking statements for any reason after the date of this presentation or to conform these statements to actual results or revised expectations. Additionally, certain information we may disclose (either herein or elsewhere) is informed by the expectations of various stakeholders or third-party frameworks and, as such, may not necessarily be material for purposes of our filings under U.S. federal securities laws, even if we use "material" or similar language in discussing such matters.

Non-GAAP Financial Measures: This presentation also includes non-GAAP financial measures. Reconciliations of the differences between non-GAAP financial measures used in this presentation and their most directly comparable GAAP financial measures are available at www.investors.merlinlabs.com in the Q126 Earnings Release.

Trademarks: This presentation may contain trademarks, service marks, trade names and copyrights of other companies, which are the property of their respective owners and Merlin Inc.'s use thereof does not imply an affiliation with, or endorsement by, the owners of such trademarks, service marks, trade names and copyrights. Solely for convenience, some of the trademarks, service marks, trade names and copyrights referred to in this Presentation may be listed without the TM, © or ® symbols, but Merlin Inc. will assert, to the fullest extent under applicable law, the rights of the applicable owners, if any, to these trademarks, service marks, trade names and copyrights.



About Merlin



Key Highlights

Merlin is the leading U.S.-based developer of cost-effective, takeoff-to-landing autonomy for both legacy and next-generation airborne systems. Our aircraft-agnostic, AI-powered software is purpose-built for military and civil programs, building on hundreds of autonomous test flights globally.

Headquartered: Boston, Massachusetts

Founded: 2018

Cash: \$183M (Post 5/1/26 financing)

Team: ~200 employees, 111 engineers

At a Glance

\$105M

USAF C-130J
Prime

\$183M

Cash Post-PIPE
(May 1)

Apr 11th & 21st

First
Auto Takeoffs

32

Cumulative
Auto Takeoffs





One **System** .
Many **Missions** .

Merlin Pilot **Addressable** Airframe Map

■ = Current Program

■ = Pipeline Opportunity

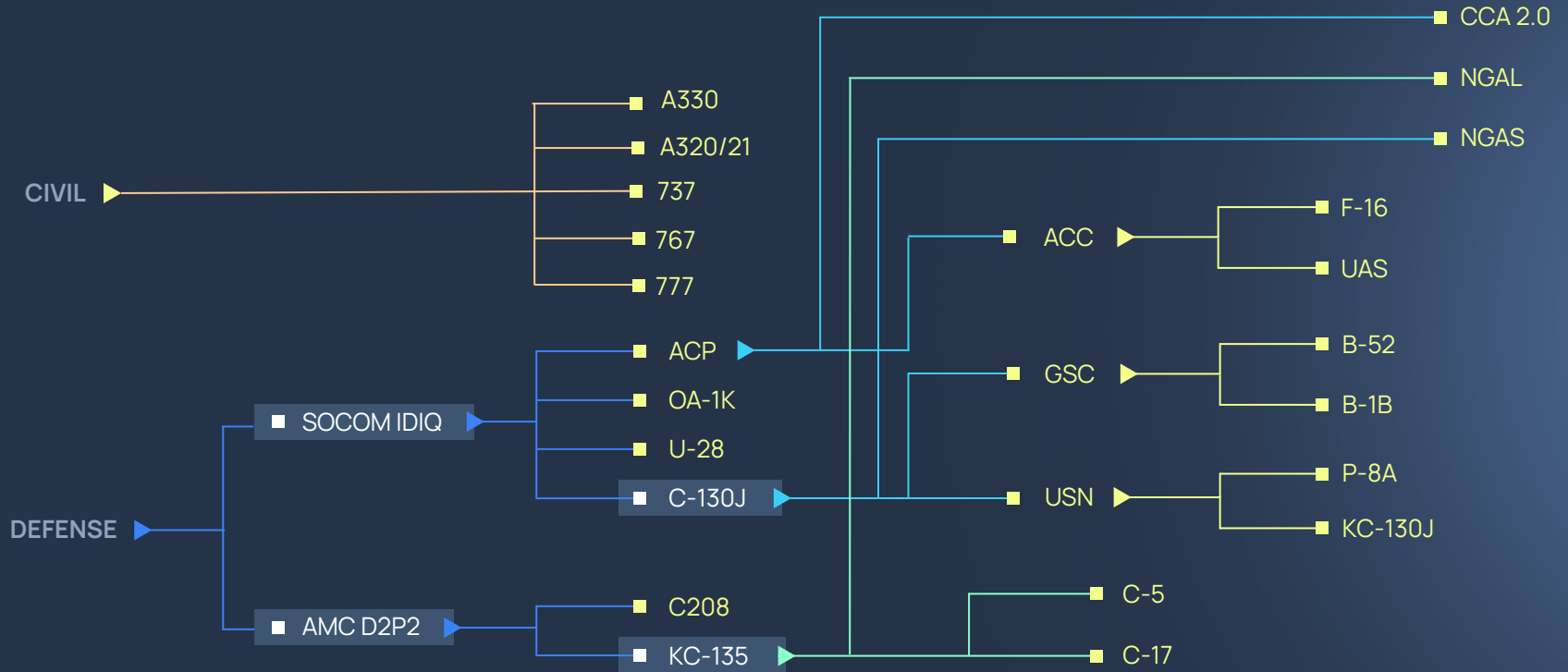

Certification

Goal: **First in the world at civil-certified, fully automated, takeoff-to-landing flight** on a fixed-wing aircraft



Defining a Merlin Product



Introducing **Condor**

Reduced crew. Large aircraft. Many missions.



Condor Goal: Crew Augmentation

Condor is Merlin's product family for large multi-crew aircraft, civil and military. The Merlin Pilot is designed to sit alongside human pilots, extend crew capabilities and make every flight safer and more productive.



Condor (civil) : Targeting commercial cargo aviation

\$8 Trillion

Value of goods transported by air each year, ~30% of all global trade ([IATA](#))

The pilot shortage is structural

Projected 30,000-pilot shortage by 2030 ([NACA](#))

In collaboration with:



Condor (defense): C-130J flagship airframe

\$105M

IDIQ Contract
Ceiling Value

Prime

Contract Status

PDR

Complete





Condor : The first product of a planned portfolio

Q1 2026 Financial Results



Q1 2026

Financial Summary (unaudited)

(\$ in thousands)	Q1 2026	Q1 2025
Revenue	\$1,002	\$868
Net Loss	(\$90,419)	(\$12,733)
Adjusted EBITDA *	(\$23,340)	(\$10,388)

*Non-GAAP Financial Measure; for a reconciliation to Net Income, its most directly comparable GAAP financial measure, see Appendix.



Q1 2026

Balance Sheet (unaudited)

	March 31, 2026	May 1, 2026
Cash, cash equivalents, & short term investments	~\$123M	~\$183M



Thank you



Appendix



Adjusted EBITDA Non-GAAP Reconciliation (unaudited)

Three Months Ended March 31,

(\$ in thousands)

	2026	2025
Net loss	\$ (90,419)	\$ (12,733)
Depreciation	417	381
Amortization of right-of-use assets	209	183
Interest income	(517)	(301)
Interest expense	9	1,614
Provision for income taxes	48	1
EBITDA	(90,253)	(10,855)
Stock-based compensation	1,295	513
Equity-based payments to non-employees	643	0
Change in fair value of warrant liabilities	(26,555)	(46)
Change in fair value of convertible promissory notes	87,824	0
Change in fair value of long-term debt	2,470	0
Transaction costs	1,236	0
Adjusted EBITDA	\$ (23,340)	\$ (10,388)